

FEOC



ANSI/ASME 2L PROCESS PUMP

SUPPLEMENT DRAWINGS ATTACHED WHEN LISTED BELOW	AVAILABLE FLANGES (ANSI B16.5)		OPTIONAL TAP CONNECTIONS	
	CLASS 150 FF <input type="checkbox"/>	CLASS 150 RF <input type="checkbox"/>	TAP	REQ. SIZE
	CLASS 300 FF <input type="checkbox"/>	CLASS 300 RF <input type="checkbox"/>	I	CASING DRAIN
	SPECIAL <input type="checkbox"/>	<input type="checkbox"/>	II	SUCTION NOZZLE CONN.
	BASEPLATE		III	DISCHARGE NOZZLE CONN.
	STEEL <input type="checkbox"/>	<input type="checkbox"/>	IV	AUXILIARY CONN.
	SPECIAL <input type="checkbox"/>	<input type="checkbox"/>	V	STUFFING BOX
			VI	BACK DRILLED SEAL FLUSH CONN.
			VII	BOTTOM TAP IN STUFFING BOX

PUMP SIZE INLET X OUTLET - MAX. IMP. DIA.	PUMP WT LBS (KG)	CP	D	D5	D6	□	U		X
							SHAFT	KEYWAY	
2L 3 X 1 1/2 - 10A	220 (100)	23 1/2 (597)	8 1/4 (210)	6 3/4 (171)	6 3/4 (171)	16 3/4 (425)	1 1/8 (29)	1/4 x 1/8 (6 x 3)	8 1/2 (216)

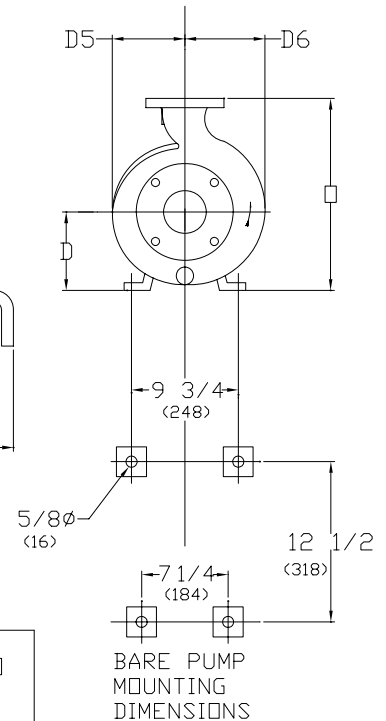
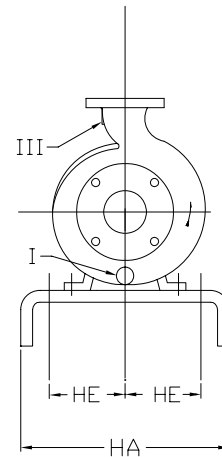
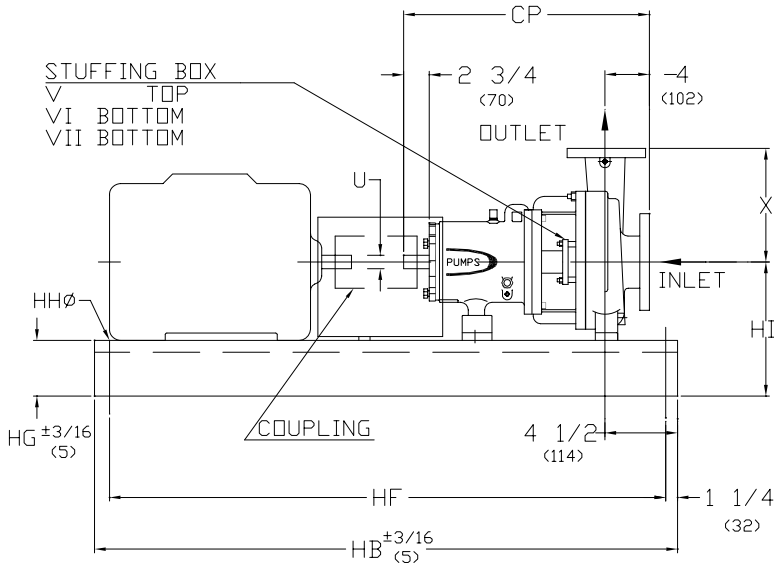

BASEPLATE AND MOUNTING DIMENSIONS

BASE	MAX MOTOR FRAME	HA	HB	HD	HE	HF	HG (NOTA 3)	HHØ	PESO lbs (kg)
245	184T	15 (381)	45 (1143)	12 (305)	4 1/2 (114)	42 1/2 (1080)	3 3/4 (95)	3/4 (19)	129 (59)
252	215T	18 (457)	52 (1321)	12 3/8 (314)	6 (152)	49 1/2 (1257)	4 1/8 (105)	3/4 (19)	129 (80)
258	286T	21 (533)	58 (1473)	13 (330)	7 1/2 (191)	55 1/2 (1410)	4 3/4 (121)	1 (25)	234 (106)
264	326T	22 (559)	64 (1626)	13 (330)	7 1/2 (191)	61 1/2 (1562)	4 3/4 (121)	1 (25)	328 (149)
	13 7/8 (352)								
268	405TS	26 (660)	68 (1727)	14 7/8 (378)	9 1/2 (241)	65 1/2 (1664)	4 3/4 (121)	1 (25)	409 (186)
280	449TS	26 (660)	80 (2032)	15 7/8 (403)	9 1/2 (241)	77 1/2 (1969)	4 3/4 (121)	1 (25)	481 (218)

1. DIMENSIONS IN PARENTHESIS () ARE IN MILLIMETERS

2. INSTALLATION DIMENSIONS ARE +- 1/8" (3) UNLESS OTHERWISE NOTED.

3. *HG* DIM. APPLIES TO THE LOWER PAD HEIGHT, WITH SOME BASES THIS WILL OCCUR AT PUMP END AND OTHERS AT MOTOR END.

CUSTOMER		CUSTOMER P.D.		CUSTOMER ITEM No.	
FEOC ORDER No.	SERIAL No.	CERTIFIED BY:	DATE		