

FEOC



ANSI/ASME 1L PROCESS PUMP

SUPPLEMENT DRAWINGS ATTACHED WHEN LISTED BELOW	AVAILABLE FLANGES (ANSI B16.5)		OPTIONAL TAP CONNECTIONS	
	CLASS 150 FF <input type="checkbox"/>	CLASS 150 RF <input type="checkbox"/>	TAP	REQ. SIZE
	CLASS 300 FF <input type="checkbox"/>	CLASS 300 RF <input type="checkbox"/>	I	CASING DRAIN
	SPECIAL <input type="checkbox"/>	<input type="checkbox"/>	II	SUCTION NOZZLE CONN.
	BASEPLATE		III	DISCHARGE NOZZLE CONN.
	STEEL <input type="checkbox"/>	<input type="checkbox"/>	IV	AUXILIARY CONN.
	SPECIAL <input type="checkbox"/>	<input type="checkbox"/>	V	STUFFING BOX
			VI	BACK DRILLED SEAL FLUSH CONN.
			VII	BOTTOM TAP IN STUFFING BOX

PUMP SIZE INLET X OUTLET - MAX. IMP. DIA.	PUMP WT LBS (KG)	CP	D	D5	D6	□	U		X
							SHAFT	KEYWAY	
1L 1 1/2 X 1BF-82	103 (47)	17 1/2 (445)	5 1/4 (133)	5 5/16 (135)	5 5/16 (135)	11 3/4 (298)	7/8 (22)	3/16 x 3/32 (4.8 x 2.4)	6 1/2 (165)

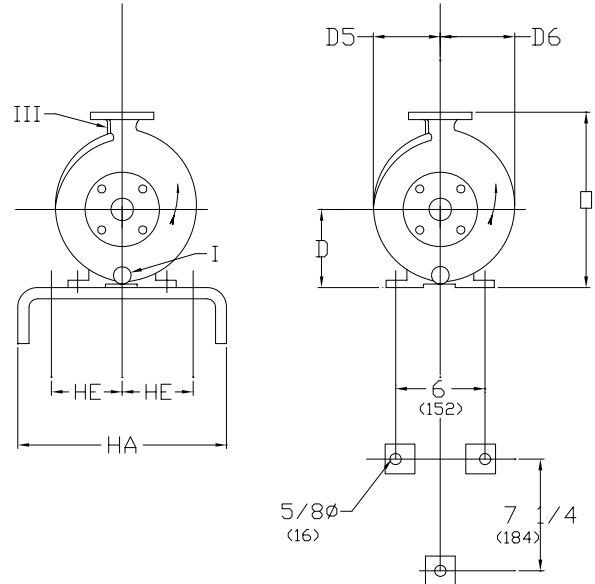
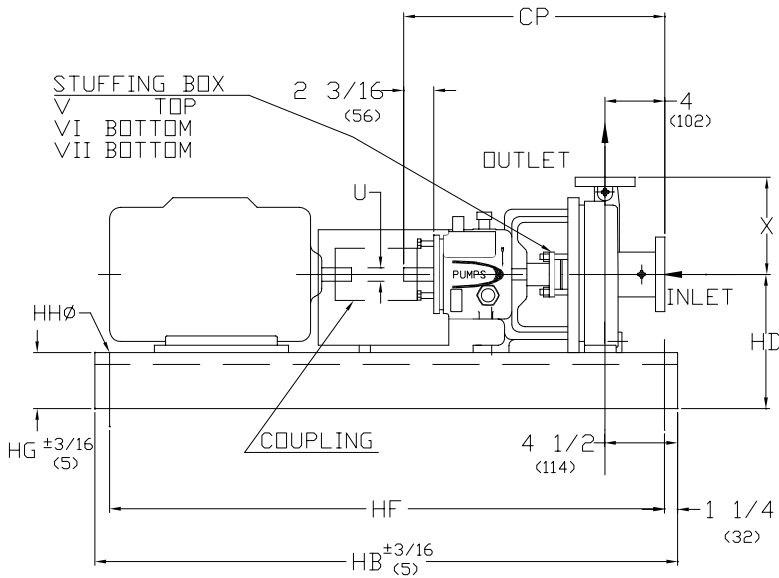

BASEPLATE AND MOUNTING DIMENSIONS

BASE	MAX MOTOR FRAME	HA	HB	HD	HE	HF	HG (NOTA 3)	HH	WEIGHT lbs (kg)
139	184T	15 (381)	39 (991)	9 (229)	4 1/2 (114)	36 1/2 (927)	3 3/4 (95)	3/4 (19)	111 (50)
148	215T	18 (457)	48 (1219)	9 1/2 (241)	6 (152)	45 1/2 (1156)	4 1/8 (105)	3/4 (19)	163 (74)
	256T			10 1/2 (267)					
153	286T	21 (533)	53 (1346)	11 7/8 (302)	7 1/2 (191)	50 1/2 (1283)	4 3/4 (121)	3/4 (19)	212 (96)
	326TS			12 7/8 (327)					

BARE PUMP MOUNTING DIMENSIONS

- DIMENSIONS IN PARENTHESIS () ARE IN MILLIMETERS
- INSTALLATION DIMENSIONS ARE +- 1/8" (3) UNLESS OTHERWISE NOTED.
- "HG" DIM. APPLIES TO THE LOWER PAD HEIGHT, WITH SOME BASES THIS WILL OCCUR AT PUMP END OTHERS AT MOTOR END.

CUSTOMER		CUSTOMER P.D.		CUSTOMER ITEM No.	
FEOC ORDER No.	SERIAL No.	CERTIFIED BY:	DATE		